

Analyzing the Performance of Multiuser MIMO Uplink System with Detection Techniques

Temple C. Okeahialam

Department of Information Technology, Federal University of Technology, Minna-Niger State, Nigeria
t.okeahialam@futminna.edu.ng

Donatus O. Njoku

Department of Computer Science, Federal University of Technology, Owerri-Imo State-Nigeria
donatus.njoku@futo.edu.ng

Gilean C. Onukwugha

Department of Computer Science, Federal University of Technology, Owerri-Imo State
onukwugha2000@yahoo.com

Ikechukwu A. Amaefule

Imo State University, Owerri, Imo State- Nigeria
profiyke24@gmail.com

Janefrances E. Jibiri

Department of Information Technology, Federal University of Technology, Owerri-Imo State-Nigeria
eberejibi@yahoo.com

-----ABSTRACT-----

This In this paper, performance analysis of multiuser multiple-input multiple-output (MU-MIMO) in terms of bit error rate (BER) against with detection techniques has been presented. With the increasing demand for wireless communication system that offers users better satisfaction, different detection schemes have been developed and implemented for uplink system. Hence, this paper was basically designed to study the effect of linear minimum mean square error (MMSE-Linear) and MMSE with signal interference cancellation (MMSE-SIC) detectors on BER performance of MU-MIMO system with based station antennas taken as 4 or 8 while the number of user equipment(UE) taken as 2, 4, or 8. Each UE is considered to be equipped with one antenna at time. A model representing the wireless communication of a MU-MIMO system in uplink scenario was developed as MATLAB program. Computer simulation was conducted using the developed model and the analysis of revealed that MMSE-SIC outperformed MMSE-linear. Nevertheless, an obvious observation was the fact with lower number of antenna at BS together with number of receive antenna of UE, the BER performance of both techniques were almost the same

Keywords - BER, Detection techniques, MMSE-Linear, MMSE-SIC, MU-MIMO.

Date of Submission: March 26, 2023

Date of Acceptance: May 27, 2023

I. INTRODUCTION

In recent times, the connections to wireless communication network by user equipments (UEs) have largely increased and this has caused increasing huge data traffic over wireless transmission channels. Also, the number of applications that is bandwidth demanding has tremendously increased as portable smart devices such as mobile phones, sensor, and other Internet of Things enable systems are being introduced into market. Furthermore, several communication services such as file sharing and video streaming, are already pushing the limits of the current wireless networks [1]. For example, while citing CVNI Forecast 2009-2014, [1] reported that between the years 2000 and 2015, the increase in mobile data traffic was 400 million times from below 10 GB every month to 3.7 EB each month respectively. This drift in data usage is not expected to stop anytime soon. Thus, recent development in wireless communication has resulted in advance technology that has seen 4G gradually being replaced by 5G and beyond.

One of the technologies that have been put forward to serve as a solution to increased high data demand by users is multiple-input multiple-output (MIMO) system. The technology of MIMO including multiuser MIMO (MU-MIMO) has been available for quite sometimes. The basic

concept of employing multi-antenna base stations to serve multiple users in wireless communication has been around for near three decades ago. With MU-MIMO improved spectral efficiency, energy efficiency, and reliability has been reported.

Though, the wireless communication is complex system, the operation of communication can be categorized into downlink and uplink. In the downlink scenario, the base station (BS) with its antenna(s) serves as the sending (or transmitting) end during communication with UEs. Conversely, UEs transmit to BS, which serves as the receiving end during uplink scenario.

In this paper, the focus will be on uplink communication in MU-MIMO system. The objective is to evaluate the performance of the system using detection techniques.

II. HEAD MIMO TECHNIQUE AND MU-MIMO SYSTEM

1. MIMO Techniques

The MIMO system uses two or more antennas at the transmitter and receiver respectively to achieve wireless communication. This technique has gain acceptability as a common choice for antenna arrangement in many modern wireless systems recently. The use of MIMO to give

improved link capacity, data rate (or speed of data transfer) and spectral efficiency is evident in Wi-Fi, Long Term Evolution (LTE) and several other radio and wireless networks. In today's market, there are many wireless routers employing the MIMO system and as such making the technology more popular and widespread. MIMO is capably a radio antenna system [9]. The use of MIMO technology for wireless communication facilitates a variety of signal paths between transmitter and receiver antennas. A number of objects that appear to the side or even in the path directly connect the transmitting end and receiving end are responsible for the available multipath. Prior to this time, interference is considered to be the cause of these multiple paths [10]. Nevertheless, with MIMO system emergence and its successive utilization in wireless communication, it becomes possible to use these additional paths to augment link capacity. Transmitted data ought to be encoded using the space-time code (STC) so as to exploit the MIMO wireless technology. The receiver is allowed to extract the original transmitted data from the received signals by the STC. The signal to noise ratio (SNR) is optimized by STC, and the performance gain to be achieved is defined by the codes. Usually, more processing power is required if more gain is achieved [10]. Illustration of MIMO system is shown in Figure 1.

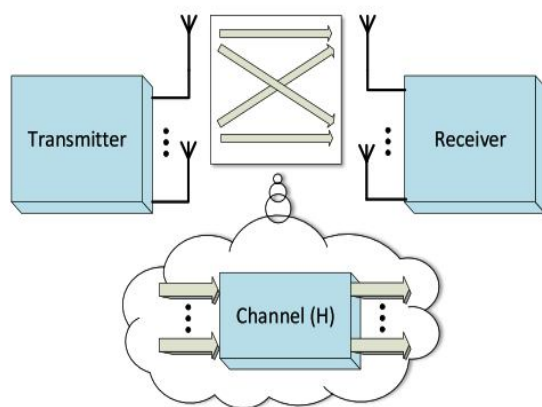

Figure 1: Architecture of MIMO system [3]

- Spatial Multiplexing

In spatial multiplexing, MIMO system is allowed to increase linearly using minimum M transmitting and N receiving antennas without employing extra transmit power or bandwidth. MIMO works just like a combination of single input multiple output (SIMO) and multiple input single output (MISO) otherwise called receive diversity and transmit diversity correspondingly. In these approaches, a combination of multiple paths signals is carried out to give a stronger signal with high SNR. Nevertheless, for MIMO, the outcome is a signal that has higher SNR gain compared with either SIMO or MISO. The possibility of this result using MIMO technique is due to the fact that total SNR is shared between multiple data streams of MIMO system such that each data stream has lower power profile. Hence, each data stream will have a lower SNR than it possibly would have had if it were a single data stream. Since every stream of data combines multipath signals again to increase its SNR, depreciation arises and every stream of data is restricted or

limited by the SNR value of the original data stream. Thus, every multiple may be able to convene approximately as much data as a single original stream [10].

- Spatial Diversity

Spatial diversity is capacity to use different “channels” for the transmission of the same data stream from transmitter antenna to receiver antenna when fading occurs in the different channels in a way not statistically dependent so that information could be recovered the channel(s) having highest SNR. This scheme is of two types namely, transmit diversity and receive diversity. Transmit diversity involves using multiple antennas at the transmitter to send coded information to a receive antenna, while receive diversity entails using a transmitted antenna to communicate coded information to multiple input receive antennas.

- Spatial Multiplexing/Spatial Diversity

Spatial multiplexing outperforms spatial diversity when both approaches are compared taking into account the situation involving high signal scattering environment and comparatively high SNR for example near the BS. On the other hand, in the case wherein the SNR is weak for example at the edge of cell, spatial diversity outperforms spatial multiplexing because spatial diversity will increase SNR and ensured data rate increase [2]. Thus, ideally, a wireless mobile telecommunication system will consist of spatial diversity and spatial multiplexing such that the system analyze the optimum crossover between both in a way that the system changes dynamically between the schemes to give the required coverage offered spatially diversity or capacity gain contributed by spatial multiplexing in terms of the condition of the channel [6].

2. Multi Multiuser MIMO

Multiuser MIMO (MU-MIMO) system, part of the computational difficulty is moved to the transmit end (that is the base station, BS). It also important to note that [11] considered a downlink MU massive MIMO system with a BS equipped with large number of users transmit antennas M and with K number of users connected in the network via a MT with one single antenna (such that $M \gg K$) the MTs are serviced by the BS at the same time. The BS has more power to carry out the computation of the channel matrix. Hence, at the transmitter side a matrix W is applied and a pre-weighting of the data is performed [5]; [8]. Figure 1 shows an illustration of MU-MIMO including their respective channel matrices.

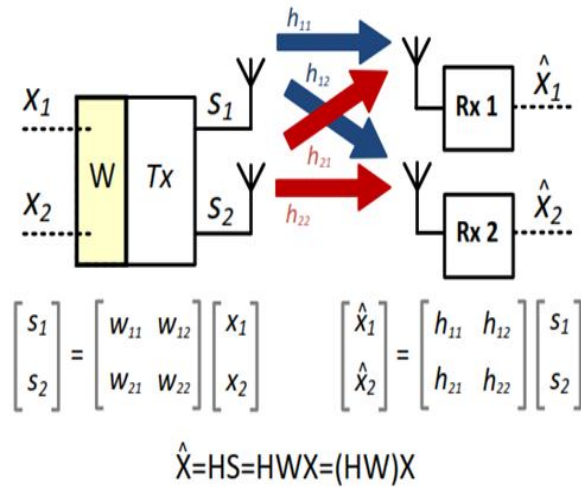

Figure 2: Architecture and channel matrix of MU-MIMO [8] During the channel coherence time, computing W requires that a number of uplink pilots are simultaneously transmitted by all the UEs. The transmitted uplink pilots are received by all BS antennas and then perform pre-weighting matrix computation. Data streams are precoded using measured magnitude and phase on account of the distance from each UE to each of the antenna array. The measured magnitude and phase are also used for distribution of data streams to each antenna port. Thus, the multiuser spatial layer separation does not need to be carried out by the receiver and each UE receives the data separately from the other UEs with better signal to interference-plus-noise ratio (SINR) [8]

In [11], presented a bit error rate (BER) analysis of multiuser (MU) massive multiple input multiple out (MIMO) wireless system using precoding techniques. The research considered the increase in demand for wireless communication that will provide seamless performance to meet users' satisfaction, the research was basically designed to examine the effect of linear zero forcing (ZF) and minimum mean square error (MMSE) precoders on BER performance on MU Massive MIMO system with up to 32 base Station antennas (BS) and communication with up to 5 user mobile terminal (MTs).

III. SYSTEM DESIGN

1. MU-MIMO Uplink Configuration

Given an uplink MU-MIMO system as shown in Fig. 3 with base station (BS) of M antennas and K users each with N antennas, the i th user channel coefficient matrix of the uplink MIMO is represented by $\mathbf{H}_i \in C^{M \times N}, (i = 1, 2, \dots, K)$. In this case; two critical constraints are to be met. First, $M \geq KN$. Also, each user should have as many transmit antennas as the transmitted data streams [7]. Let $\mathbf{x}_i \in C^{N \times 1}, (i = 1, 2, \dots, K)$ denotes the data streams of the i th user, which are considered to be zero-mean white random transmitted symbols vector each with unit-energy. With linear precoder \mathbf{W}_i applied for each user, at the BS, the received vector symbol is given by:

$$y = \sum_{i=1}^K \mathbf{H}_i \mathbf{x}_i + \mathbf{n} \quad (1)$$

where \mathbf{n} is the zero-mean white Gaussian noise vector.

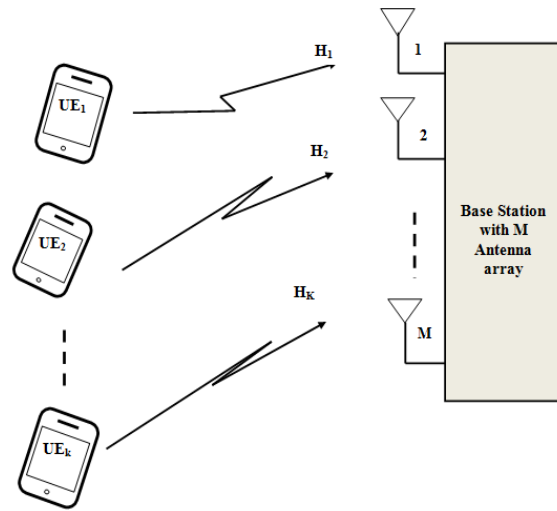

Figure 3: Block diagram of uplink communication

2. Detection Techniques

This section presents the detection schemes considered in this paper. The two techniques are the linear minimum mean square error (MMSE-Linear) and MMSE with signal interference cancellation (MMSE-SIC).

The MMSE is detection technique used to suppress both the interference and noise components. This means that the detector ensure the minimization of the mean square error between the transmitted symbols and the estimate of the receiver.

The mathematical expression for MMSE for i th data stream is given by:

$$\mathbf{W}_i = \left(\mathbf{H}_i \mathbf{H}_i^* + \frac{1}{SNR} \mathbf{I} \right)^{-1} \mathbf{H}_i^* \quad (2)$$

Where \mathbf{H}_i is the Rayleigh fading channel with independent, identically distributed (i.i.d.), and \mathbf{H}_i^* is the complex conjugate of \mathbf{H}_i . SNR is signal to noise ratio.

In the case of SIC scheme based MMSE criterion, the algorithm is given by:

$$\mathbf{W}_{iSIC} = \left(\mathbf{H}_i^H \mathbf{H}_i + \sigma_n^2 \mathbf{I} \right)^{-1} \mathbf{H}_i^H \quad (3)$$

where the \mathbf{H} in the superscript in Eq. (3) denotes the Hermitian transpose and σ_n^2 is the variance of noise.

3. Performance Parameters

The metrics considered in analysis the system is the relationship between bit error ratio (BER) against SNR. For \mathbf{H}_i is a Rayleigh distributed channel, which is a random variable, given the resultant SNR, the overall BER is an

average quantity and not an instantaneous quantity given by [9]:

$$BER = \int_0^\infty Q\left(\sqrt{\frac{\alpha^2 P}{\sigma_n^2}}\right) 2\alpha e^{-\alpha^2/d\alpha} \quad (4)$$

The BER is related to the Signal to Noise Ratio (SNR) by:

$$BER = \frac{1}{2} \left(\sqrt{\frac{SNR}{2+SNR}} \right) \quad (5)$$

At high SNR, the expression in Eq. (5) is reduced to:

$$BER \cong \frac{1}{2 \times SNR} \quad (6)$$

IV. SIMULATION RESULTS

The parameters of the system used for the simulations carried out in this paper are $M = 4, 8$; $K = 2, 4, 8$; $N = 2, 4, 8$; SNR of 25 dB; packet size of 1000, and signal square root is equal 1. The modulation technique is QPSK. The simulations were conducted by varying the number of antennas M at the BS, the number of users K , and the number of N antennas of UE. The graphical plots of the computer simulation analysis carried out using MATLAB program for MU-MIMO with linear MMSE and SIC MMSE are presented in Fig. 4 for $M = 4, K = N = 2$; Fig. 5 for $M = 4, K = N = 4$; Fig. 6 for $M = 8, K = N = 2$; Fig. 7 for $M = 8, K = N = 4$; and Fig. 8 for $M = 8, K = N = 8$. In all cases it was assumed that each user on the network is equipped with UE of a single antenna, and $M \geq N$.

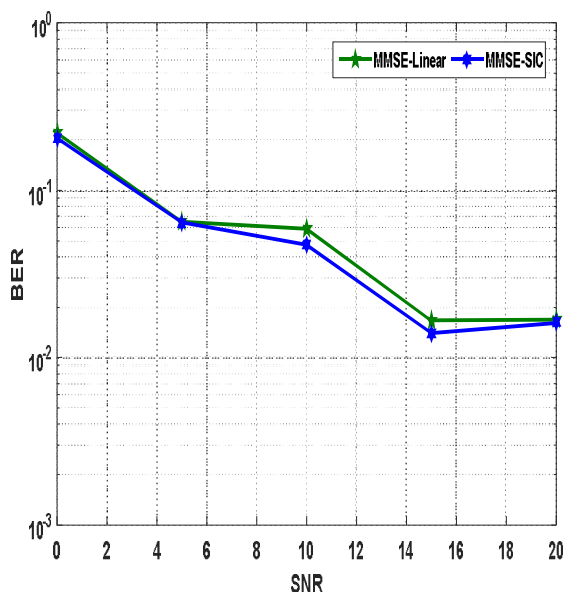

Figure 4: BER against SNR for $M = 4, K = N = 2$

Figure 4 is the performance analysis curves for linear MMSE and SIC MMSE in terms of BER against SNR. The simulation analysis indicates that with $M = 4, K = N = 2$, BERs of 0.01688 and 0.01619 at SNR = 25 were respectively produced by MMSE-Linear and MMSE-SIC detectors.

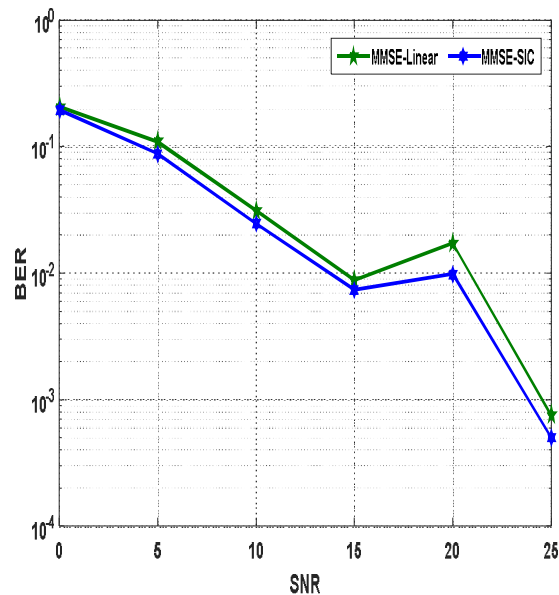

Figure 5: BER against SNR $M = 4, K = N = 4$

The simulation analysis curves shown in Figure 5 revealed that the BER performance of the system when $M = 4, K = N = 4$ was 0.00075 with MMSE-Linear and 0.0005 with MMSE-SIC at SNR of 25 respectively.

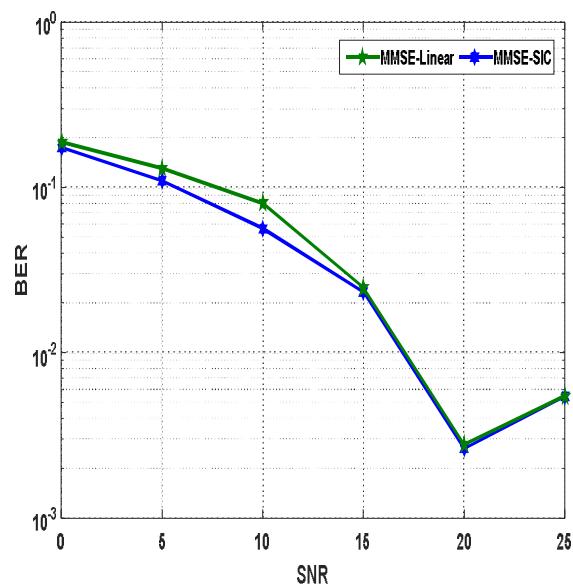

Figure 6 BER against SNR for $M = 8, K = N = 2$

In Figure 6, the BER curves of MMSE-Linear and MMSE-SIC are presented for antenna arrangement $M = 8, K = N = 2$. The analysis revealed that BERs of 0.002781 and 0.002625 at SNR =20 were obtained using MMSE-Linear and MMSE-SIC respectively.

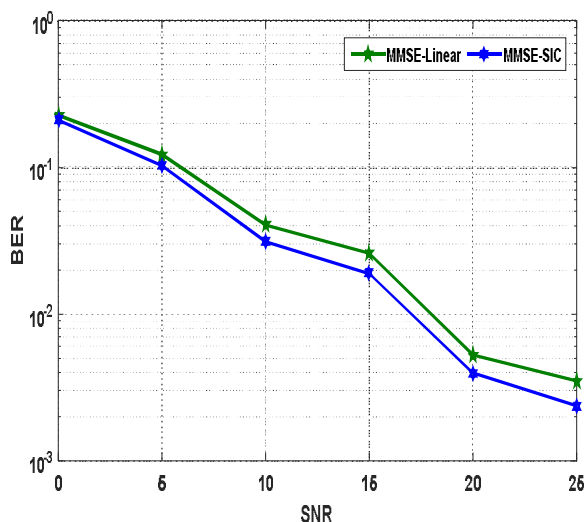

Figure. 7: BER against SNR for $M = 8, K = N = 4$

With the number of BS antenna $M = 8$, and the number of users K equal to number of receive antennas (at UE) $N = 4$ (i.e. $M = 8, K = N = 4$), the MMSE-linear produced BER of 0.0035 while MMSE-SIC provided BER of 0.002359 at SNR = 25 respectively.

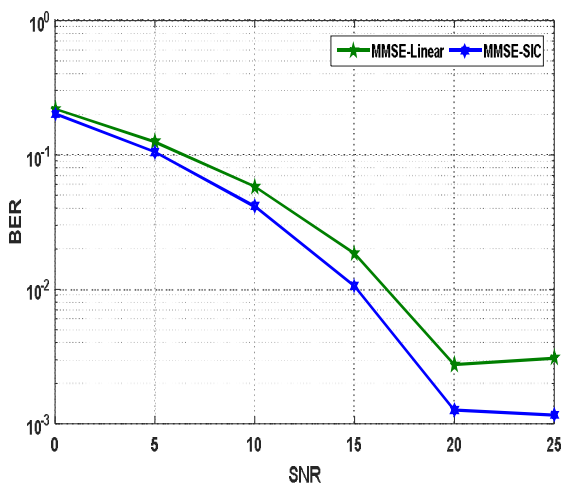

Figure. 8: BER against SNR for $M = 8, K = N = 8$

In this case, the system is analyzed considering the system configuration to be $M = 8, K = N = 8$. The performance curves as shown in Fig. 8 revealed that MMSE-Linear provided BER of 0.003078 while MMSE-SIC produced BER of 0.001156 at SNR = 25.

V. CONCLUSION

The MATLAB simulation analysis has shown the performance of MMSE-Linear and MMSE-SIC detector for MU-MIMO system operating in uplink scenario with number of BS antennas greater than or equal to number of receive antennas. The simulation curves presented have shown that increasing the number of BS antennas together with number of UE results in improved BER. The results revealed that MMSE-SIC provides better performance than

MMSE-Linear. However, an obvious observation is the fact with lower number of antenna at BS together with number of receive antenna of UE, the BER performance of both techniques were almost the same. Generally, this paper was designed to examine the influence of the considered detectors on the BER performance of MU-MIMO system in uplink mode. The simulation has revealed that MMSE-SIC will outperform MMSE-linear in terms of BER with increased antenna array.

REFERENCES

- [1]. A. Alshammari, Optimal capacity and energy efficiency of massive MIMO systems [Doctoral dissertation, University of Denver]. Electronic Thesis and Dissertation, 2017, <https://digitalcommons.du.edu/etd/1377>
- [2]. J. Andrews, G. W. Choi, & R.W. Heath, Overcoming interference in spatial multiplexing mimo cellular networks. IEEE Wireless Communications, 2006, 1-24.
- [3]. D. Borges, P. Montezuma, R. Dinis, & M. Boko. Massive MIMO techniques for 5G and beyond – opportunities and challenges. Electronics, 10(1667), 2021, 1 – 29. <https://doi.org/10.3390/electronics10141667>
- [4]. S.Y. Cho, J. Kim, W.Y. Yang & G.C. Kang, MIMO-OFDM Wireless Communications with MATLAB, John Wiley & Sons (Asia) Pte Ltd., 2010.
- [5]. B. Clerckx, & C. Oestges MIMO Wireless Networks: Channels Techniques and Standards for Multi-Antenna, Multi-User and Multi-Cell Systems. (Cambridge: Academic Press, 2013) 225-237
- [6]. D. Gesbert, M. Shafi, D. Shiu, D., P.J. & Smith. Theory to Practice: an Overview of MIMO Space-time Coded wireless system. IEEE Journal on Selected Areas in communications, 21(3), 2003, 281-302.
- [7]. C-C Hu, & C-L. Yang, Combined transceiver optimization for uplink multiuser MIMO with limited CSI. International Scholarly Research Network, (20) 11, 2011 doi:10.5402/2011/735695
- [8]. S. A. Khwandah, J.P. Cosmas, P.I. Lazaridis, Z. Zaharis, & I. P. Chochilouros. Massive MIMO systems for 5G communications. Wireless Personal Communications, 12(10), 2021, 2101 – 2115. <https://doi.org/10.1007/s11277-021-08550-9>
- [9]. C. S. Shreelakshmi, N. S., Shettar, & A. V. Srikantan, Adaptive monitoring technique for MIMO-OFDM systems. GSSS Institute Of Engineering And Technology For Women, Mysuru, (National Level PG Project Symposium On Electronics & Communication, Computer Science, 2016), 1-4.
- [10]. B. C. Agwah, M. I. Aririguzo (2020), MIMO-OFDM system in wireless communication: a survey of peak to average power ratio minimization and research direction, International Journal of Computer Science Engineering, 9 (4) , 2020, 219-234
- [11]. C. G. Onukwugh, D.O. Njoku, J.E. Jibiri, & Chigozie D (2023), Bit Error Rate Analysis of Multiuser Massive MIMO Wireless System Using Linear Precoding Techniques, Int. J. Advanced Networking and Applications, 14(4), 20223, 5517-5522